

Jinko Solar Photovoltaic Module

—Eagle Dual



Installation Manual

Solar
Jinko
Building Your Trust in Solar

Contents

1	General Information	1
1.1	Overview	1
1.2	Applicable Products	1
1.3	Warnings	1
<hr/>		
2.	Installation	3
2.1	Installation safety	3
2.2	Installation Condition	4
2.2.1	Climate condition	4
2.2.2	Site selection	4
2.2.3	Tilt angle selection	5
2.3	Mechanical Installation introduction	6
<hr/>		
3	Wiring and connection	10
<hr/>		
4	Maintenance and care	10
4.1	Visual Inspection	11
4.2	Cleaning	11
4.3	Inspection of Connector and Cable	11
<hr/>		
5	Electrical specification	12
<hr/>		
6	Disclaimer of Liability	12
<hr/>		

1. General Information

1.1 Overview

Thanks for choosing Jinko Solar PV modules. In order to ensure the PV modules to be installed correctly, please read the following operation instructions carefully before modules installed and used.

Please remember that the products would generate electricity and certain safety measures need to be taken to avoid danger.

1.2 Applicable Products

This document is applicable to the series of solar module as listed below:

JKMxxxPP-72-DV、JKMSxxxPP-72-DV、JKMxxxPP-72-DV-J、JKMSxxxPP-72-DV-J、JKMxxxPP-60-DV、JKMSxxxPP-60-DV、JKMxxxPP-60-DV-J、JKMSxxxPP-60-DV-J、JKMxxxPP-48-DV、JKMSxxxPP-48-DV、JKMxxxPP-48-DV-J、JKMSxxxPP-48-DV-J、JKMxxxPP-36-DV、JKMSxxxPP-36-DV、JKMxxxPP-36-DV-J、JKMSxxxPP-36-DV-J



1.3 Warnings

- PV modules generate DC electrical energy when exposed to sunlight or other light sources. Active parts of module such as terminals can result in burns, sparks, and lethal shock.
- Artificially concentrated sunlight shall not be directed on the module or panel.



- Front protective glass is utilized on module. Broken solar module glass is an electrical safety hazard (may cause electric shock and fire). These modules cannot be repaired and should be replaced immediately.

 Warning	<ul style="list-style-type: none"> ◆ Electric Shock and Burn Hazard ◆ This photovoltaic module produces Electricity when exposed to the sun
--	---

- To reduce the risk of electrical shocks or burns, modules may be covered with an opaque material during installation to avoid shocks or burns.
- The installation work of the PV array can only be done under the protection of sun-sheltering covers or sunshades and only qualified person can install or perform maintenance work on this module.
- Follow the battery manufacture's recommendations if batteries are used with module.
- Do not use this module to replace or partly replace roofs and walls of living buildings.
- Do not install modules where flammable gas may be present.
- Do not touch live terminals with bare hands. Use insulated tools for electrical connections.

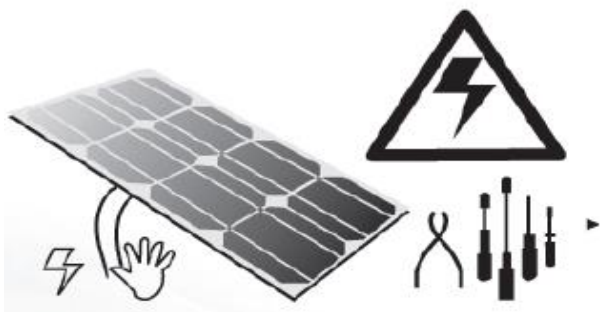

Use insulated tools for electrical connection

- Do not remove any part installed by Jinko Solar or disassemble the module.
- All instructions should be read and understood before attempting to install, wire, operate and maintain the module.
- Please don't lift up PV modules using the attached cables or the junction box.
- All PV systems must be earthed. If there is no special regulation, please follow the National Electrical Code or other national code.
- Under normal conditions, a photovoltaic module is likely to experience conditions that produce more current and/or voltage than reported at standard test conditions. Accordingly, the value of I_{sc} and V_{oc} marked on this module should be multiplied by 1.25 when determining component voltage ratings, conductor current ratings, fuse sizes, and size of controls connected to the PV output.

- Once the PV module has been shipped to the installation site, all of the parts should be unpacked properly with care.
- Do not stand or step on the PV module like below pictures show, this is prohibited and there can be risks of micro-crack which may cause a sharp decline of module's power performance; what's more, it may threaten your safety.

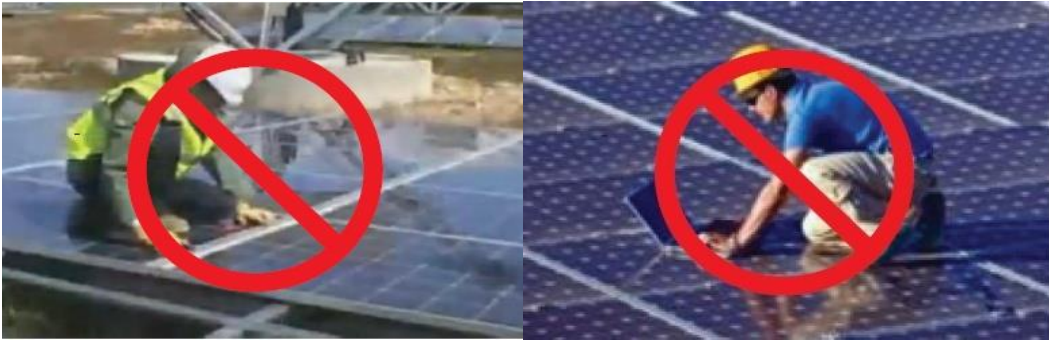

- Only PV modules with the same cell size should be connected in series.
- During all transportation situations, please make sure no huge shock for the vehicle or the modules, as this may damage the module or lead the cell to be crack.
- During all transportation situation, never let the module fall down from the vehicle, house or hands. This will break the cells of the modules.
- Do not clean the glass with chemicals.
- Do not disconnect any of the modules when it is under load.
- Corner protection of DV module is used to protect the module during transportation, and the customer can remove or leave it on modules.

2. Installation

2.1 Installation safety

- Always wear protective head gear, insulating gloves and safety shoes (with rubber soles).
- Keep the PV module packed in the carton until installation.
- Do not touch the PV module unnecessarily during installation. The glass surface may be hot. There is a risk of burns and electric shock.
- Do not work in rain, snow or windy conditions.
- Due to the risk of electrical shock, do not perform any work if the terminals of the PV module are wet.
- Use insulated tools and do not use wet tools.

- When installing PV modules, do not drop any objects (e.g., PV modules or tools).
- Make sure flammable gasses are not generated or present near the installation site.
- Insert interconnect connectors fully and correctly.
- Do not touch the terminal box and the end of the interconnect cables (connectors) with bare hands during installation or under sunlight, regardless of whether the PV module is connected to or disconnect from the system.
- Do not expose the PV module to excessive loads on the surface of the PV module.
- Do not hit or put excessive load on the glass, this may break the cells or cause micro crack.
- During the operation, don't use sharp tools to wipe glass. It would leave scratch on the module.
- For BIPV mounting structure, when install the modules, please try to follow the "from top to bottom" and/or "from left to right" principle, and don't step on the module, that will damage the module and would be dangerous for personal safety.

2.2 Installation Condition

2.2.1 Climate condition

Please install the modules in the following conditions:

- 1) The environment temperature: within $-40^{\circ}\text{C}(-4^{\circ}\text{F})$ to $85^{\circ}\text{C}(185^{\circ}\text{F})$.
- 2) Do not install modules in a place where there may be water immersion.

* Note: The mechanical load bearing (include wind and snow loads) of the module is based on the mounting methods. The professional system installer must be responsible for mechanical load calculation according to the system design.

2.2.2 Site selection

In most applications, Jinko solar PV modules should be installed in a location where they will receive maximum sunlight throughout the year. In the Northern Hemisphere, the module should typically face south, and in the Southern Hemisphere, the modules should typically face north. Modules facing 30 degrees away from true South (or North) will lose approximately 10 to 15 percent of their power output. If the module faces 60 degrees away from true South (or North), the power loss will be 20 to 30 percent.

When choosing a site, avoid trees, buildings or obstructions, which could cast shadows on the solar photovoltaic modules especially during the winter months when the arc of the sun is lowest over the horizon. Shading causes loss of output, even though the factory fitted bypass diodes of the PV module will minimize any such loss. Do not install the PV module near naked flame or flammable materials.

When solar modules are used to charge batteries, the battery must be installed in a manner, which will protect the performance of the system and the safety of its users. Follow the battery manufacturer's guidelines concerning installation, operation and maintenance recommendations. In general, the battery (or battery bank) should be away from the main flow of people and animal traffic. Select a battery site that is protected from sunlight, rain, snow, debris, and is well ventilated. Most batteries generate hydrogen gas when charging, which can be explosive. Do not light matches or create sparks near the battery bank. When a battery is installed outdoors, it should be placed in an insulated and ventilated battery case specifically designed for the purpose.

Do not install the PV module in a location where it would be immersed in water or continually exposed to water from a sprinkler or fountain etc.

2.2.3 Tilt angle selection

The tilt angle of the PV module is measured between the surface of the PV module and a horizontal ground surface (Figure 1). The PV module generates maximum output power when it faces the sun directly.

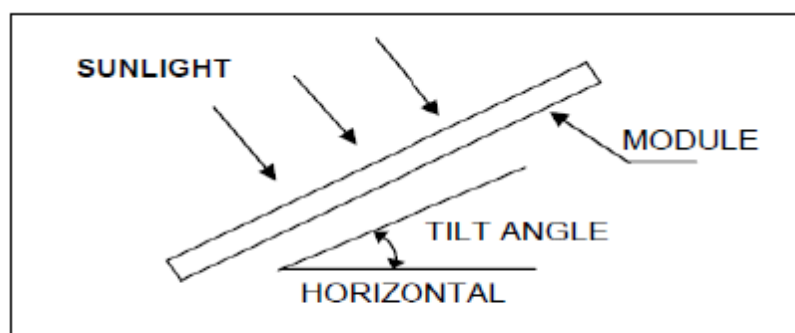

Figure1: PV module title angle

For standalone systems with batteries where the PV modules are attached to a permanent structure, the tilt angle of the PV modules should be selected to optimize the performance based on seasonal load and sunlight. In general, if the PV output is adequate when irradiance is low (e.g., winter), then the angle chosen should be



adequate during the rest of the year. For grid-connected installations where the PV modules are attached to a permanent structure, PV modules should be tilted so that the energy production from the PV modules will be maximized on an annual basis.

2.3 Mechanical Installation introduction

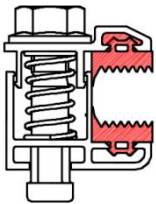
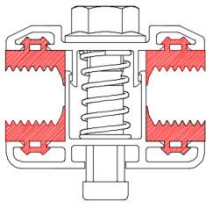
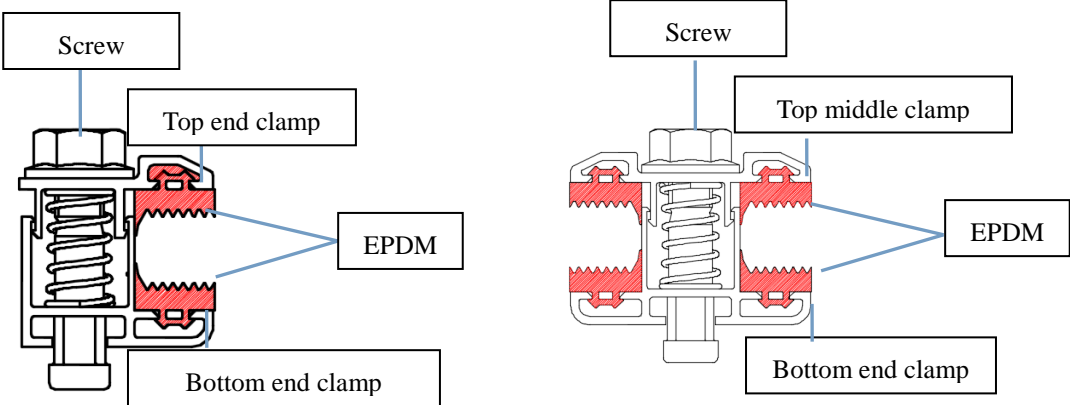
Jinko Eagle Dual modules usually can be mounted by the clamps.

Following components are just used in manual Jinko Eagle Dual module.		
clamp	Example	Description
End clamp		Connect the last module of each PV row
Middle clamp		Connect two modules
		

Be sure to avoid shadowing effects from the module clamps. When choosing this type of clamp-mounting method, please be sure to use at least four clamps on each module, and two clamps should be attached on each long side of the module. Depending on the local wind and snow loads, if excessive pressure load is expected, additional clamps or support would be required to ensure the module can bear the load. The applied torque should be large enough to fix it steadily (about 16-20 N·m) . For safety, you'd better follow the clamps manufacture's recommendation. Please find detailed mounting information in the below illustration, and we suggest the clamps are mounted between J and K, as shown below.

Type	JKMxxxPP-60-DV、JKMSxxxPP-60-DV、JKMxxxPP-60-DV-J、JKMSxxxPP-60-DV-J、JKMxxxPP-48-DV、JKMSxxxPP-48-DV、JKMxxxPP-48-DV-J、JKMSxxxPP-48-DV-J、JKMxxxPP-36-DV、JKMSxxxPP-36-DV、JKMxxxPP-36-DV-J、JKMSxxxPP-36-DV-J	
Mechanical Load Pressure	Length	Manual direction
Front surface: ≤2400 Pa Black surface: ≤2400 Pa	85mm	
Front surface: ≤5400 Pa Black surface: ≤2400 Pa	150mm	 <p>Note: The middle of the clamp should be between J and K, J=300mm, K=400mm</p>

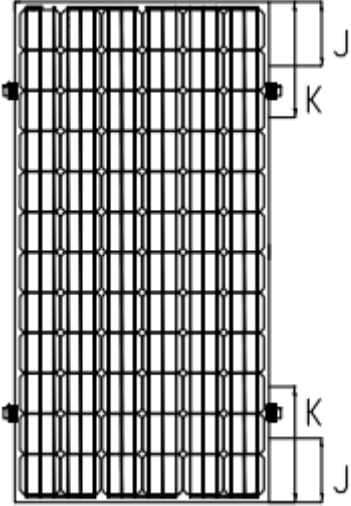
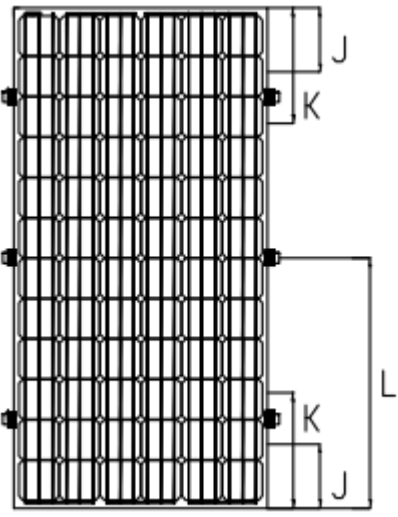
Type	JKMxxxPP-72-DV、JKMSxxxPP-72-DV、JKMxxxPP-72-DV-J、JKMSxxxPP-72-DV-J	
Mechanical Load Pressure	Length	Manual direction
Front surface: ≤ 2400 Pa Black surface: ≤ 2400 Pa	150mm	<div style="text-align: center;">  </div> <p style="text-align: center;"> Note: The middle of clamp should be between J and K, J=300mm, K=400mm </p>
Front surface: ≤ 5400 Pa Black surface: ≤ 2400 Pa	120mm	<div style="text-align: center;">  </div> <p style="text-align: center;"> Note: using 3 rails under 5400Pa, and the middle of clamp should be between J and K, J=300mm, K=400mm, L=1/2 module length </p>

Before the installation, please read the operation instructions of the PV system carefully. In addition, please completely prepare the site before the installation.

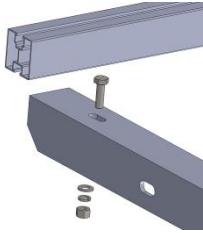
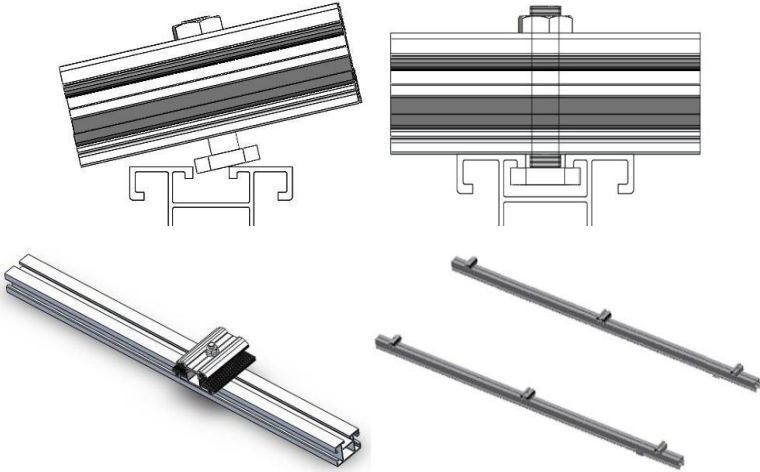
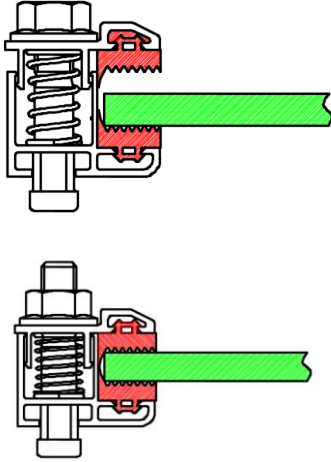
<p>Step 1: Install the rail</p>	
<p>Install the rail</p>	
<p>Step 2: Install the clamp</p>	
<p>Put the clamp into the rails</p>	
<p>Step 3: Install the module</p>	
<p>Put the module into the clamp and tighten the screw (about 16-20N·m)</p>	

3. Wiring and connection

- a) Before this procedure, please read the operation instructions of the PV system carefully. Make wiring by Multi-connecting cables between the PV modules in series or parallel connection, which is determined by user's configuration requirement for system power, current and voltage.
- b) PV module connected in series should have similar current. Modules must not be connected together to create a voltage higher than the permitted system voltage (1500VDC). The maximum number of modules in series depends on system design, the type of inverter used and environmental conditions.
- c) The maximum fuse rating value in an array string can be found on the product label or in the product datasheet. The fuse rating value is also corresponding to the maximum reverse current that a module can withstand. Thus based on the maximum series fuse rating of module and local electrical installation criteria, make sure the modules strings in parallel for connection need to be assembled with appropriate string fuse for circuit protection.
- d) Open the connection box of the control system and connect the cabled from the PV arrays to the connection box in accordance with the installation indication of the PV control systems. The cross-sectional area and cable connector capacity must satisfy the maximum short-circuit of PV system (For a single component, were commended the cross-sectional area of cables is 4mm² and the rated current of connectors is more than 10A), otherwise cables and connectors will become over heating for large current. Please pay attention: the temperature limit of cables is 85 °C .
- e) Follow the requirements of applicable local and national electrical codes.
- f) These modules contain factory installed bypass diode .if these modules are in correctly connected to each other, the bypass diodes, cable or junction box may be damaged.

4. Maintenance and care

It is required to perform regular inspection and maintenance of the modules, especially within warranty scope. To ensure optimum module performance, Jinko recommends the following maintenance measures:

4.1 Visual Inspection

Inspect the Modules visually to find whether there are appearance defects, the following need to be paid more attention especially:

- a) Corner protection of DV module is used to protect the module during transportation, not refer to quality control for visual inspection and the customer can remove or leave it on modules;
- b) Whether the glass is broken;
- c) No sharp objects are in contact with the PV module surfaces
- d) PV modules are not shaded by unwanted obstacles and/or foreign material
- e) Corrosion along the cells' bus-bar. The corrosion is caused by the dampness infiltrated into the Modules because that the surface encapsulation materials are damaged during the installation or transportation.
- f) Check fixing screws and mounting brackets are tight, adjust and tighten as necessary.

4.2 Cleaning

- a) A built up of dust or dirt on the module(s) front face will result in a decreased energy output. Clean the panel(s) preferably once per annum if possible (depend on site conditions) using a soft cloth dry or damp, as necessary. Water with high mineral content may leave deposits on the glass surface and is not recommended.
- b) Never use abrasive material under any circumstances.
- c) In order to reduce the potential for electrical and thermal shock, Jinko recommends cleaning PV modules during early morning or late afternoon hours when solar radiation is low and the modules are cooler, especially in regions with hotter temperatures.
- d) Never attempt to clean a PV module with broken glass or other signs of exposed wiring, as this presents a shock hazard.

4.3 Inspection of Connector and Cable

It's recommended to implement the following preventive maintenance every 6 months:

- a) Check the sealing gels of the junction box to ensure it have no crack or crevice.
- b) Examine the PV module(s) for signs of deterioration. Check all wiring for possible rodent damage, weathering and that all connections are tight and corrosion free. Check electrical leakage to ground.

5. Electrical specification

The module electrical rating are measured under Standard Test Conditions, which are $1000\text{W}/\text{m}^2$, irradiance with AM 1.5 spectrum and 25 deg (77°F) ambient temperature. The module might produce more or less voltage or current than rating value in uncertainty condition. Accordingly, the values of I_{SC} and V_{OC} marked on this module should be multiplied by a factor of 1.25 when determining component voltage ratings, conductor current ratings, fuse sizes, and size of controls connected to the PV output.

The corresponding electrical specification can be downloaded from website www.jinkosolar.com.

6. Disclaimer of Liability

Because the use of the manual and the conditions or methods of installation, operation, use and maintenance of photovoltaic (PV) product are beyond Jinko's control, Jinko does not accept any legal responsibility and expressly disclaims liability for any person and property damage arising from the failure to follow the installation, operation, use, maintenance provided in the manual, and for any disputes caused by no-quality reasons.

Intellectual Property Right: No responsibility is assumed by Jinko for any infringement of intellectual property or other rights of third parties, which may result from use of the PV product. No license is granted by implication or otherwise under any intellectual property rights or related use authorization.

Jinko reserve the right to change the manual, the PV produce, the specifications or product information. Any information may be changed due to business needs, technical level or other objective environment, which is not representative of the negation for the original information.

The information in this manual is based on Jinko's knowledge and experience and is believed to be reliable, but such information and suggestions (without limitations), which is not the only and proprietary approach, do not constitute security and quality assurance, expresses or implied.

Note

Global Sales & Marketing Center

Jinko Building
#99 Shouyang Road, Jingan District,
Shanghai, China 200027
Tel: +86 21 5183 8777
Fax: +86 21 5180 8600

Jiangxi Manufacture Base

No.1 Jinko Road,
Shangrao Economic Development Zone,
Jiangxi Province, China 334100
Tel:+86 793 858 8188
Fax:+86 793 846 1152

Zhejiang Manufacture Base

No.58 Yuanxi Road,
Haining Yuanhua Industrial Park,
Zhejiang Province, China 314416
Tel: +86 573 8798 5678
Fax: +86 573 8787 1070