

# JinkoSolar Photovoltaic Module



**User Manual (UL1703)**

**1500V**

*Solar*  
**Jinko**  
*Building Your Trust in Solar*

## Contents

1	General Information	1
1.1	Overview	1
1.2	Applicable Products	1
1.3	Warnings	2
<hr/>		
2.	Installation	5
2.1	Installation safety	5
2.2	Installation Condition	7
2.2.1	Climate condition	7
2.2.2	Site selection	7
2.2.3	Tilt angle selection	8
2.3	Mechanical Installation introduction	9
2.3.1	Fixation with screws	10
2.3.2	Fixation with clamps	11
<hr/>		
3	Wiring and connection	12
<hr/>		
4	Maintenance and care	14
<hr/>		
5	Electrical specification	15
<hr/>		
6	Disclaimer of Liability	18
<hr/>		
7	Contact us	20

## 1. General Information

### 1.1 Overview

Thanks for choosing Jinko Solar PV modules. In order to ensure the PV modules to be installed correctly, please read the following operation instructions carefully before modules are installed and used.

Please remember that the products would generate electricity and certain safety measures need to be taken to avoid danger.

### 1.2 Applicable Products

This document is applicable to the series of solar module as listed below:

UL1500V:

JKMxxxP-72-V\* (xxx=250-330, in increment of 5)

JKMxxxPP-72-V\*\* (xxx=250-330, in increment of 5)

JKMxxxPP-72-V(Plus)\*\*\* (xxx=250-330, in increment of 5)

JKMxxxP-60-V (xxx=200~275, in increment of 5)

JKMxxxPP-60-V (xxx=200~275, in increment of 5)

JKMxxxPP-60-V(Plus) (xxx=200~275, in increment of 5)

Notes:

\*V: Module with 1500V

\*\*PP: the EAGLE Series module

\*\*\*(Plus): the EAGLE+ Series module

Make sure the array of modules installed with the Maximum permitted system voltage and the rating current and voltage of the sub-equipments such as regulators and inverters. The maximum permitted system voltage (DC) of the modules (UL 1500V series) sold in America and Canada is 1500V.

This module has a Class C Fire Rating (only in Canada) or Module Fire performance type 1 (only in America) and must be installed over a roof which is with appropriate

fire resistance. Before mounting the module, please consult your local building department to determine approved roofing materials.

The modules are qualified for application class A, and modules qualified for safety through UL1703 within this application class are considered to meet the requirements of Safety Class II.

The Fire rating is Class C in Canada, but the Module Fire performance is type 1 in America with the specified construction in below table, when used with a listed mounting system that has been rated as a Class A System when installed with type 1 modules, is suitable to maintain the System Class A Fire Rating in America.

Module model	Specific construction	Marking
All	Superstrate: 3.2~4.0 mm thick; EVA: 0.25~0.6 mm thick; Substrate: 0.3015 mm ~ 0.445 mm thick; Frame: Types "40mm by 20mm" or "40mm by 35mm"	Module Fire Performance: Type 1

### 1.3 Warnings

PV modules generate DC electrical energy when exposed to sunlight or other light sources. Active parts of module such as terminals can result in burns, sparks, and lethal shock.

- Artificially concentrated sunlight shall not be directed on the module or panel.



- Front protective glass is utilized on module. Broken solar module glass is an electrical safety hazard (electric shock and fire). These modules cannot be repaired and should be replaced immediately.

 Warning	<ul style="list-style-type: none"><li>◆ Electric Shock and Burn Hazard</li><li>◆ This photovoltaic module produces Electricity when exposed to the sun</li></ul>
--	--

- To reduce the risk of electrical shocks or burns, modules may be covered with an opaque material during installation to avoid shocks or burns.
- The fire rating of this module is valid only when mounted in the manner specified in the mechanical mounting instructions.
- The module is considered to be in compliance with UL 1703 only when the module is mounted in the manner specified by the mounting instructions below.
- All installations must be performed in compliance with the National Electrical Code (NEC) and modules installed in Canada need to follow Canadian electric code.
- A module with exposed conductive parts is considered to be in compliance with UL 1703 only when it is electrically grounded in accordance with the instructions presented below and the requirements of the National Electrical Code.
- Any module without a frame (laminated) shall not be considered to comply with the requirements of UL 1703 unless the module is mounted with hardware that has been tested and evaluated with the module under this standard or by a field inspection certifying that the installed module complies with the requirements of UL 1703.
- The installation work of the PV array can only be done under the protection of sun-sheltering covers or sunshades and only qualified person can install or perform maintenance work on this module.
- Follow the battery manufacturer's recommendations, if batteries are used with module.
- Do not use this module to replace or partly replace roofs and walls of living buildings.
- Do not install modules where flammable gas may be present.
- Do not touch live terminals with bare hands. Use insulated tools for electrical connections.



- Do not remove any part installed by Jinko Solar or disassemble the module.
- All instructions should be read and understood before attempting to install, wire, operate and maintain the module.
- Please don't lift up PV modules using the attached cables or the junction box.
- All PV systems must be grounded. If there is no special regulation, please follow the National Electrical Code or other national code.
- Common hardware items such as nuts, bolts, star washers, lock washers and the like have not been evaluated for electrical conductivity or for use as grounding devices and should be used only for maintaining mechanical connections and holding electrical grounding devices in the proper position for electrical conductivity. Such devices, where supplied with the module and evaluated through the requirements in UL 1703, may be used for grounding connections in accordance with the instructions provided with the module.
- Under normal conditions, a photovoltaic module is likely to experience conditions that produce more current and/or voltage than reported at standard test conditions. The requirements of the National Electrical Code (NEC) in Article 690 shall be followed to address these increased outputs. In installations, not under the requirements of the NEC, the value of  $I_{sc}$  and  $V_{oc}$  marked on this module should be multiplied by a factor of 1.25 when determining component voltage ratings, conductor ampacities, overcurrent device ratings, and size of controls connected to the PV output.
- Once the PV module has been shipped to the installation site, all of the parts should be unpacked properly with care.
- Do not stand or step on the PV module like below pictures show, this is prohibited and there is a risk of damage the module and cause injury for you.

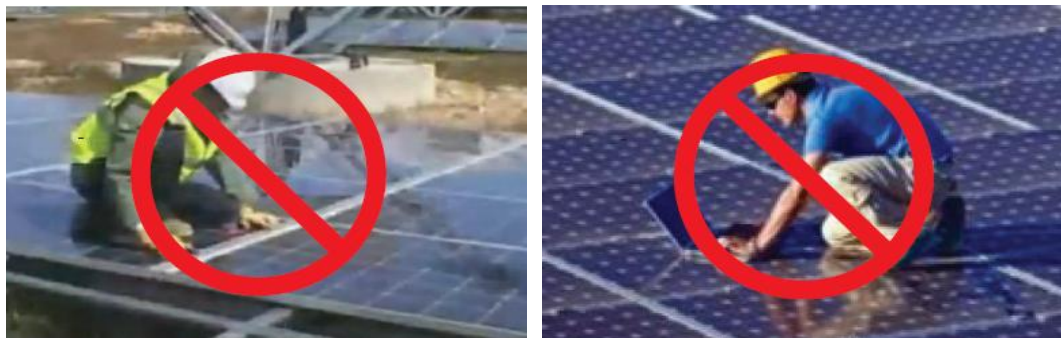

- Only PV modules with the same cell size should be connected in series.
- During all transportation situations, please make sure no huge shock for the vehicle or the modules, as this may damage the module or lead the cell to be crack.
- During all transportation situation, never let the module fall down from the vehicle, house or hands. This will break the cells of the modules.
- Do not clean the glass with chemicals.
- Do not disconnect any of the modules when it is under load.
- The recommended standoff height is 15cm. If other mounting means are employed this may affect the UL Listing.
- PV modules using the anti-reflection coating technology, it's normal if there will be color difference when observe modules at different angles

## 2. Installation

### 2.1 Installation safety

- Always wear protective head gear, insulating gloves and safety shoes (with rubber soles).
- Keep the PV module packed in the carton until installation.
- Do not touch the PV module unnecessarily during installation. The glass surface and the frame may be hot. There is a risk of burns and electric shock.
- Do not work in rain, snow or windy conditions.
- Due to the risk of electrical shock, do not perform any work if the terminals of the PV module are wet.
- Use insulated tools and do not use wet tools.
- When installing PV modules, do not drop any objects (e.g., PV modules or tools).

- Make sure flammable gasses are not generated or present near the installation site.
- Insert interconnect connectors fully and correctly. Check all connections. The interconnect cable should be securely fastened to the module frame, Cable support should be done in a way to avoid the connector from scratching or impacting the back sheet of the module.
- Do not touch the junction box and the end of the interconnect cables (connectors) with bare hands during installation or under sunlight, regardless of whether the PV module is connected to or disconnect from the system.
- Do not expose the PV module to excessive loads on the surface of the PV module or twist the frame.
- Do not hit or put excessive load on the glass or back sheet, this may break the cells or cause micro crack.
- During the operation, don't use sharp tools to wipe the back sheet and glass, it would leave scratch on the module.
- Do not drill holes on the frame, it may cause corrosion of the frame.
- For roof mounting structure, when install the modules, please try to follow the "from top to bottom" and/or "from left to right" principle, and don't step on the module, that will damage the module and would be dangerous for personal safety and roof mounting applications the assembly is to be mounted over a fire resistant roof covering rated for the application.
- The following UL Listed Ground Clamp in combination with the following model number PV modules

Model series	Grounding Clip	
	Manufacturer	Type
JKMxxxP-72-V JKMxxxPP-72-V JKMxxxPP-72-V(Plus) JKMxxxP-60-V JKMxxxPP-60-V JKMxxxPP-60-V(Plus)	Tyco Electronics Corp	1954381-1

## 2.2 Installation Condition

### 2.2.1 Climate condition

Please install the modules in the following conditions:

- a) Operating temperature: within  $-40^{\circ}\text{C}$  ( $-4^{\circ}\text{F}$ ) to  $85^{\circ}\text{C}$  ( $185^{\circ}\text{F}$ )
- b) Humidity:  $< 85\text{RH}\%$ .

\* Note: The mechanical load bearing (include wind and snow loads) of the module is based on the mounting methods. The professional system installer must be responsible for mechanical load calculation according to the system design.

### 2.2.2 Site selection

In most applications, Jinko Solar PV modules should be installed in a location where they will receive maximum sunlight throughout the year. In the Northern Hemisphere, the module should typically face south, and in the Southern Hemisphere, the modules should typically face north. Modules facing 30 degrees away from true South (or North) will lose approximately 10 to 15 percent of their power output. If the module faces 60 degrees away from true South (or North), the power loss will be 20 to 30 percent.

When choosing a site, avoid trees, buildings or obstructions, which could cast shadows on the solar photovoltaic modules especially during the winter months when the arc of the sun is lowest over the horizon. Shading causes loss of output, even though the factory fitted bypass diodes of the PV module will minimize any such loss. Do not install the PV module near naked flame or flammable materials.

When solar modules are used to charge batteries, the battery must be installed in a manner, which will protect the performance of the system and the safety of its users. Follow the battery manufacturer's guidelines concerning installation, operation and maintenance recommendations. In general, the battery (or battery bank) should be away from the main flow of people and animal traffic. Select a battery site that is protected from sunlight, rain, snow, debris, and is well ventilated. Most batteries generate hydrogen gas when charging, which can be explosive. Do not light matches or create sparks near the battery bank. When a battery is installed outdoors, it should be placed in an insulated and ventilated battery case specifically designed for the purpose.

Do not install the PV module in a location where it would be immersed in water or continually exposed to water from a sprinkler or fountain etc.

### 2.2.3 Tilt angle selection

The tilt angle of the PV module is measured between the surface of the PV module and a horizontal ground surface (Figure 1). The PV module generates maximum output power when it faces the sun directly.

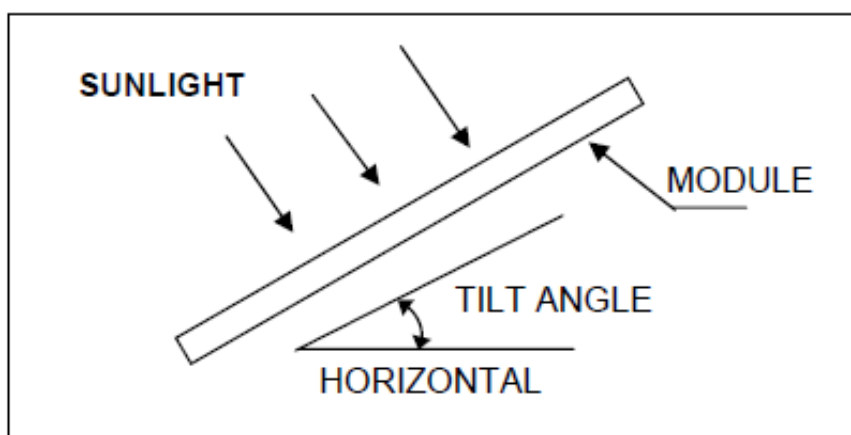

Figure1: PV module title angle

For standalone systems with batteries where the PV modules are attached to a permanent structure, the tilt angle of the PV modules should be selected to optimize the performance based on seasonal load and sunlight. In general, if the PV output is adequate when irradiance is low (e.g., winter), then the angle chosen should be adequate during the rest of the year. For grid-connected installations where the PV modules are attached to a permanent structure, PV modules should be tilted so that the energy production from the PV modules will be maximized on an annual basis.

Only for UL listed products -

The System Fire Class Rating of the module or panel in a mounting system in combination with a roof covering complete with requirements to achieve the specified System Fire Class Rating for a non-BIPV module or panel.

Any module or panel mounting system limitations on inclination required to maintain a specific System Fire Class Rating.

## 2.3 Mechanical Installation introduction

Solar PV modules usually can be mounted by using the following methods: screws and clamps.

**\* Note:**

- (1) All installation methods herein are only for reference, and Jinko Solar will not provide related mounting components, the system installer or trained professional personnel must be responsible for the PV system's design, installation, and mechanical load calculation and security of the system.
- (2) Before installing, you should confirm below important things:
  - a) Visual check before installation, to make sure there is no bug in the packing and junction box as well as the surface of module, If have , remove and clean it .
  - b) Check the series number is right or not.
  - c) The minimum distance between modules should be more than 10mm for all installation methods.
- (3) Jinko modules are designed to meet a maximum positive (or downward) pressure of 3600Pa and negative (or upward) pressure of 1600Pa. When mounting modules in snow-prone or high-wind environments, Special care should be taken to mount the modules in a manner that provides sufficient design strength while meeting local code requirements.
- (4) Where common grounding hardware (nuts, bolts, star washers, spilt-ring lock washers, flat washers and the like) is used to attach a listed grounding/bonding device, the attachment must be made in conformance with the grounding device manufacturer's instructions.

Common hardware items such as nuts, bolts, star washers, lock washers and the like have not been evaluated for electrical conductivity or for use as grounding devices and should be used only for maintaining mechanical connections and holding electrical grounding devices in the proper position for electrical conductivity. Such devices, where supplied with the module and evaluated through the requirements in UL 1703, may be used for grounding connections in accordance with the instructions provided with the module.

### 2.3.1 Fixation with screws

The frame of each module has 8 mounting holes (Length\* Width: 14mm\*9mm) used to secure the modules to support structure. You can use the four symmetry holes close to the inner side on module frame. If excessive wind or snow load are expected, you must use all the eight mounting holes. The module frame must be attached to a mounting rail using M8 corrosion-proof screws together with spring washers and flat washers in eight symmetrical locations on the PV module. The applied torque value should be big enough to fix the modules steadily. The reference value for M8 screw is 16~20N\*m. As to special support system or special installation requirement, please reconfirm with the support's supplier for the torque value. Please find detailed mounting information in the below illustration.

The following is M8 stainless steel mounting hardware.

Eight 14x9 holes, mounting hardware are shown as below:

Module	Mounting hardware configuration			
	Hardware	Material	Size	Number provided
All	Bolt	Stainless steel	M8	4
	Spring washer	Stainless steel	M8	4
	Nut	Stainless steel	M8	4

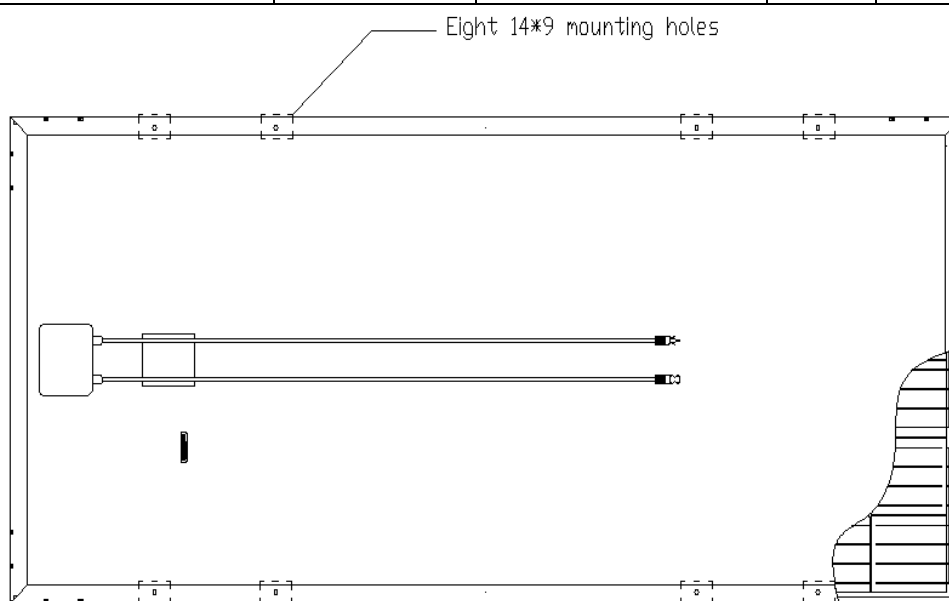

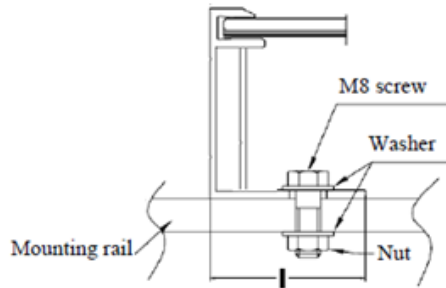
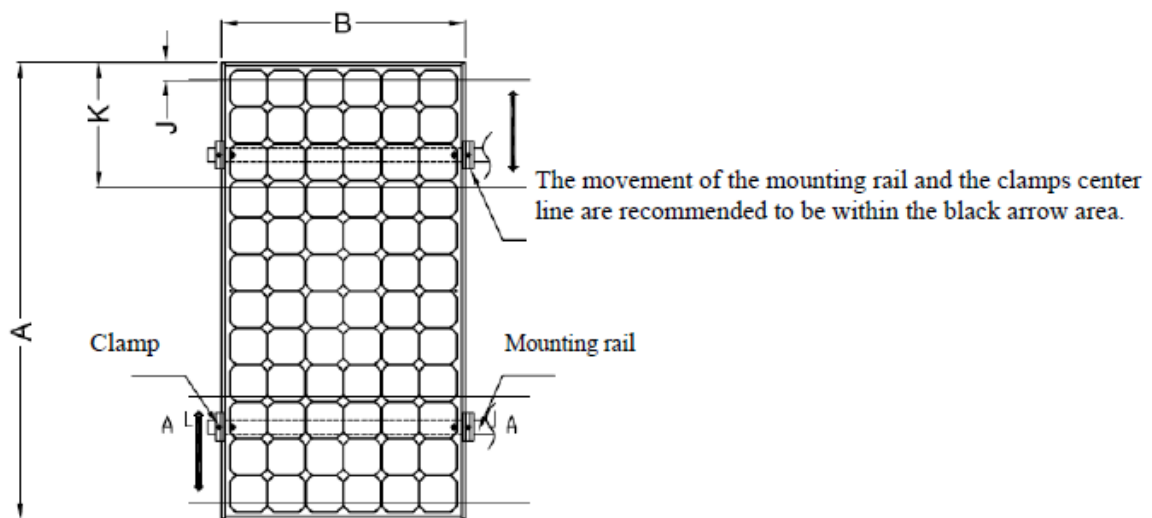

Figure 2 above: PV module installed with Screw fitting method\*

### 2.3.2 Fixation with clamps

The applicable products only allow using clamps at long side of frames.

The module clamps should not come into contact with the front glass and must not deform the frame. Be sure to avoid shadowing effects from the module clamps. The module frame is not to be modified under any circumstances. When choosing this type of clamp-mounting method, please be sure to use at least four clamps on each module, two clamps should be attached on each long side of the module. The applied torque value should be big enough to fix the modules steadily (Please consult with the clamp or support's supplier for the specific torque value). Please find detailed mounting information in the below illustration, the mounting place distance is suggested bigger than J and less than K, as showed below.



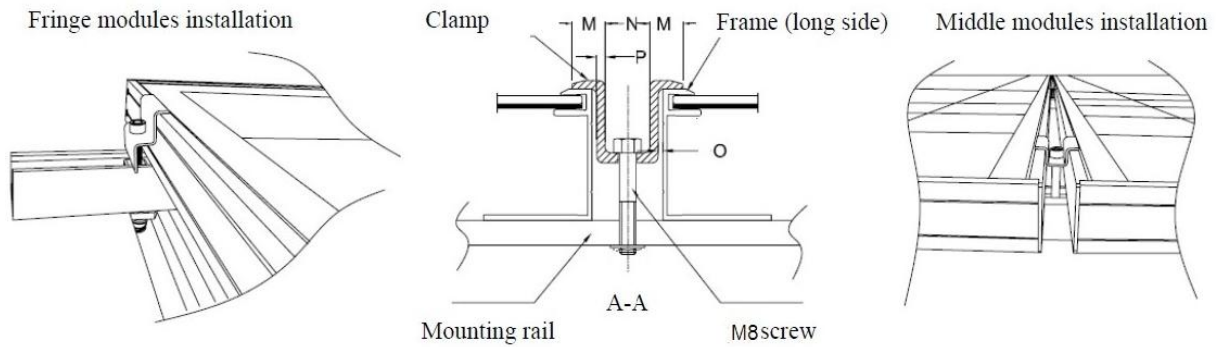

**Figure 3 above: PV module installed at long side with Clamp fitting method**

Module type	Cell type	Cell quantity	Dimension(mm)						
			A*B	J	K	M	O	N	P
JKMxxxP-72-V JKMxxxPP-72-V JKMxxxPP-72-V(Plus)	Poly	6*12	1956*992	400	480	5~11	0.5~2mm	≥14	>2mm
JKMxxxP-60-V JKMxxxPP-60-V JKMxxxPP-60-V(Plus)	Poly	6*10	1650*992	400	420	5~10	0.5~2mm	≥14	>2mm

**Table 1 above: Mechanical dimensions when modules installed at long side with Clamp**

Clamp type	Dimension	Composition material
Fringe Clamp	39 x 50 x 42 mm	Aluminum-alloy
Middle Clamp	42 x 50 x 28 mm	

**Table 2 above: The specification & material of clamp**

### 3. Wiring and connection

- a) Before this procedure, please read the operation instructions of the PV system carefully. Make wiring by Multi-connecting cables between the PV modules in series or parallel connection, which is determined by user's configuration requirement for system power, current and voltage.
- b) PV module connected in series should have similar current, and modules must not be connected together to create a voltage higher than the permitted system voltage. The maximum number of modules in series depends on system design, the type of inverter used and environmental conditions.

- c) The maximum fuse rating value in an array string can be found on the product label or in the product datasheet. The fuse rating value is also corresponding to the maximum reverse current that a module can withstand, i.e. when one string is in shade then the other parallel strings of modules will be load by the shade string and the current will pass through to create a current circuit. Thus based on the maximum series fuse rating of module and local electrical installation criteria, make sure the modules strings in parallel for connection need to be assembled with appropriate string fuse for circuit protection.
- d) Open the connection box of the control system and connect the cable from the PV arrays to the connection box in accordance with the installation indication of the PV control systems. The cross-sectional area and cable connector capacity must satisfy the maximum short-circuit of PV system (For a single component, we recommended the cross-sectional area of cables is  $4\text{mm}^2$  and the rated current of connectors is more than 10A), otherwise cables and connectors will become overheated from large current. Please pay attention the temperature limit of cables is  $85^{\circ}\text{C}$ .
- e) All module frames and mounting racks must be properly grounded in accordance with local and national electrical codes. It is recommended that the applied torque is 2.3 to 2.8Nm.  
Jinko modules can be grounded using third party ground washers or clip devices (Use Tyco: 1954381-1) as long as the products are approved for grounding metallic frames of PV modules.  
Alternate grounding options built into the racking system are acceptable so long as they have been UL approved.
- f) Follow the requirements of applicable local and national electrical codes.
- g) These modules contain factory installed bypass diode, if these modules are incorrectly connected to each other, the bypass diodes, cable or junction box may be damaged.
- h) The module shall wire in accordance with the NEC, the grounding method of the frame of arrays shall comply with the NEC, article 250.
- i) CNL model shall be in accordance with CSA C22.1, Safety Standard for Electrical Installations, Canadian Electrical Code, Part 1.
- j) It is recommended that the M8 screw be tightened to a torque of about  $16\sim 20\text{N}\cdot\text{m}$ .
- k) The cable of the junction box is defined as L1, as showed below. For Jinko standard module, L1 is 900 /1200mm; and for customized module, L1 can be

based on your condition, take the cable length into consideration before designing the wiring layout.

- I) Jinko Solar requires the negative grounding of the inverter when a system is installed with standard (non-Eagle line) PV solar modules. Alternatively, a 'charge-equalizing' device may be used to mitigate the effects of the Potential Induced Degradation (PID) phenomenon that can occur in specific environments that the array is installed in.



Figure 4 above: Junction box

## 4. Maintenance and care

- a) A built up of dust or dirt on the module(s) front glass will result in a decreased energy output. Clean the module(s) preferably once annually if possible (depend on site conditions) using a soft cloth dry or damp, as necessary.
- b) Never use abrasive material under any circumstances.
- c) Examine the PV module(s) for signs of deterioration. Check all wiring for possible rodent damage, weathering and that all connections are tight and corrosion free. Check electrical leakage to ground.
- d) Check fixing screws and mounting brackets are tight, adjust and tighten as necessary.
- e) Check the junction box and diodes are well. If you have any diodes problem, please contact Jinko Solar.
- f) When cleaning the modules, it is not allowed to stand on the module. See below pictures shown, this is prohibited.



## 5. Electrical specification

The module electrical rating are measured under Standard Test Conditions, which are  $1000\text{W}/\text{m}^2$ , irradiance with AM 1.5 spectrum and 25 deg (77°F) ambient temperature. The module might produce more or less voltage or current than rating value in uncertainty condition. Tables below are electrical characteristics of PV products at STC and the tolerance of  $I_{sc}$ ,  $V_{oc}$ ,  $V_{mp}$  and  $I_{mp}$  is  $\pm 3\%$ .

## 5.1. Electrical specifications of JKMxxxP-72-V, JKMxxxPP-72-V, and JKMxxxP-72-V(Plus) (xxx=250-330) Series polycrystalline solar modules

Module Type	JKMxxxP-72-V, JKMxxxPP-72-V, JKMxxxP-72-V(Plus)																
xxx =	250	255	260	265	270	275	280	285	290	295	300	305	310	315	320	325	330
Maximum Power at STC (Pmax, Wp)	250	255	260	265	270	275	280	285	290	295	300	305	310	315	320	325	330
Maximum Power Voltage (Vmp, V)	34.2	34.5	34.7	34.9	35.0	35.2	35.3	35.5	35.8	36.2	36.6	36.8	37.0	37.2	37.4	37.6	37.8
Maximum Power Current (Imp, A)	7.31	7.39	7.49	7.59	7.71	7.81	7.93	8.03	8.11	8.15	8.20	8.30	8.38	8.48	8.56	8.66	8.74
Open-circuit Voltage (Voc, V)	43.5	43.7	43.9	44.1	44.2	44.4	44.5	44.7	44.9	45.1	45.3	45.6	45.9	46.2	46.4	46.7	46.9
Short-circuit Current (Isc, A)	8.05	8.18	8.26	8.33	8.43	8.49	8.58	8.61	8.69	8.76	8.84	8.91	8.96	9.01	9.05	9.1	9.14
Maximum system Voltage	1500VDC																
Dimensions	1956x992x40mm (77.01x39.06 x1.57 inch)																
Maximum series overcurrent protective device rating	15A																

## 5.2. Electrical specifications of JKMxxxP-60-V, JKMxxxPP-60-V, and JKMxxxP-60-V(Plus) (xxx=200-275) Series polycrystalline solar modules

Module Type	JKMxxxP-60-V, JKMxxxPP-60-V , JKMxxxP-60-V(Plus)															
xxx =	200	205	210	215	220	225	230	235	240	245	250	255	260	265	270	275
Maximum Power at STC (Pmax, Wp)	200	205	210	215	220	225	230	235	240	245	250	255	260	265	270	275
Maximum Power Voltage (Vmp, V)	28.2	28.4	28.6	28.8	29.0	29.2	29.4	29.6	29.8	30.1	30.5	30.8	31.1	31.4	31.7	32.0
Maximum Power Current (Imp, A)	7.09	7.22	7.34	7.47	7.59	7.71	7.82	7.94	8.06	8.14	8.20	8.28	8.37	8.44	8.52	8.61
Open-circuit Voltage (Voc, V)	35.3	35.5	35.8	36.1	36.3	36.6	36.8	37.0	37.3	37.5	37.7	38.0	38.1	38.6	38.8	39.1
Short-circuit Current (Isc, A)	8.09	8.18	8.25	8.31	8.41	8.48	8.56	8.65	8.71	8.76	8.85	8.92	8.98	9.03	9.09	9.15
Maximum system Voltage	1500VDC															
Dimensions	1650x992x40mm (64.97x39.06 x1.57 inch)															
Maximum series overcurrent protective device rating	15A															

## 6. Disclaimer of Liability

Because the use of the manual and the conditions or methods of installation, operation, use and maintenance of photovoltaic (pv) product are beyond Jinko's control, Jinko does not accept responsibility and expressly disclaims liability for loss, damage, or expense arising out of or in any way connected with such installation, operation, use or maintenance.

No responsibility is assumed by Jinko for any infringement of patents or other rights of third parties, which may result from use of the PV product. NO license is granted by implication or otherwise under any patent or patent rights.

The information in this manual is based on Jinko's knowledge and experience and is believed to be reliable, but such information including product specification (without limitations) and suggestions do not constitute a warranty, expresses or implied. Jinko reserves the right to change the installation manual, the PV product, the electrical specifications, or product information sheets without prior notice.

### Note

---

---

---

---

---

---

---

---

## 7. Contact us

Jinko Solar Co., Ltd. (Shanghai Office)  
Jinko Building, #99 Shouyang Road, Jingan District, Shanghai, China  
Postcode: 200127  
Tel : (86)-21-51838777  
Fax : (86)-21-51808600

Jinko Solar Co., Ltd. (Jiangxi Manufacture base)  
No.1 Jinko Road, Shangrao Economic Development Zone, Jiangxi Province,  
China  
Postcode: 334100  
Tel: (86)-793-8588188  
Fax: (86)-793-8461152

Jinko solar Import and Export co., LTD  
Xuri District, Shangrao Economic Development Zone, Jiangxi Province,  
CHINA  
Postcode: 334100  
Tel: +86-793-8618987  
Fax: +86-793-8461152  
Customer Service : cs@jinkosolar.com

Jinko Solar USA  
495 Market Street, Suite 2200, San Francisco, CA 94105  
Tel: +(415) 402 0502  
Fax: +(415) 402 0703  
us@jinkosolar.com

Jinko Solar Canada Co., Ltd.  
Suite 703, 100 Allsate Parkway, Markham, ON Canada L3R 6H3  
Tel: +1 905 604 2527  
Fax: +1 905 604 2687  
canada@jinkosolar.com

**Global Sales & Marketing Center**

Jinko Building  
#99 Shouyang Road, Jingan District,  
Shanghai, China 200027  
Tel: +86 21 5183 8777  
Fax: +86 21 5180 8600

**Jiangxi Manufacture Base**

No.1 Jinko Road,  
Shangrao Economic Development Zone,  
Jiangxi Province, China 334100  
Tel:+86 793 858 8188  
Fax:+86 793 846 1152

**Zhejiang Manufacture Base**

No.58 Yuanxi Road,  
Haining Yuanhua Industrial Park,  
Zhejiang Province, China 314416  
Tel: +86 573 8798 5678  
Fax: +86 573 8787 1070